

**TEEC**

**ATLAS PUMP INDUX<sup>®</sup>**

Slurry pumping solutions

**SPS**

Submersible Slurry Pump

Mining | Coal Washing | Power Plant | Dredging



**ATLAS EQUIPMENT MANUFACTURING LTD., HEBEI, CHINA**

Website: [www.atlas-pump.com](http://www.atlas-pump.com)

Address: 201# Taihang St. Hi-tech Zone, Shijiazhuang, China 050035

**Sales Dept:**

Tel: 86-311-85832151 / 85832152

Fax: 86-311-8777076

Email: [sales@atlas-pump.com](mailto:sales@atlas-pump.com)

**Marketing Dept:**

Tel: 86-311-85832212

Fax: 86-311-8777076

Email: [marketing@atlas-pump.com](mailto:marketing@atlas-pump.com)



## SPS SUBMERSIBLE SLURRY PUMP

SPS is a Single stage, single suction, single casing, submerged overhang shaft centrifugal slurry pump, designed to handle abrasive and corrosive slurries in applications such as mining and mineral processing, power plants, refining, coal preparation etc. ,providing excellent performance when dealing with corrosive slurries contain crystals.

- Discharge size: 65mm-200mm
- Capacity to: 700m<sup>3</sup>/h
- Head to: 45m

### Model Number Description

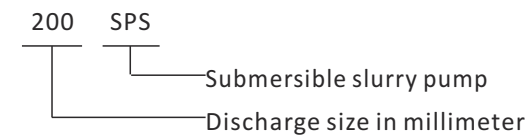

## PUMP SELECTION CHART

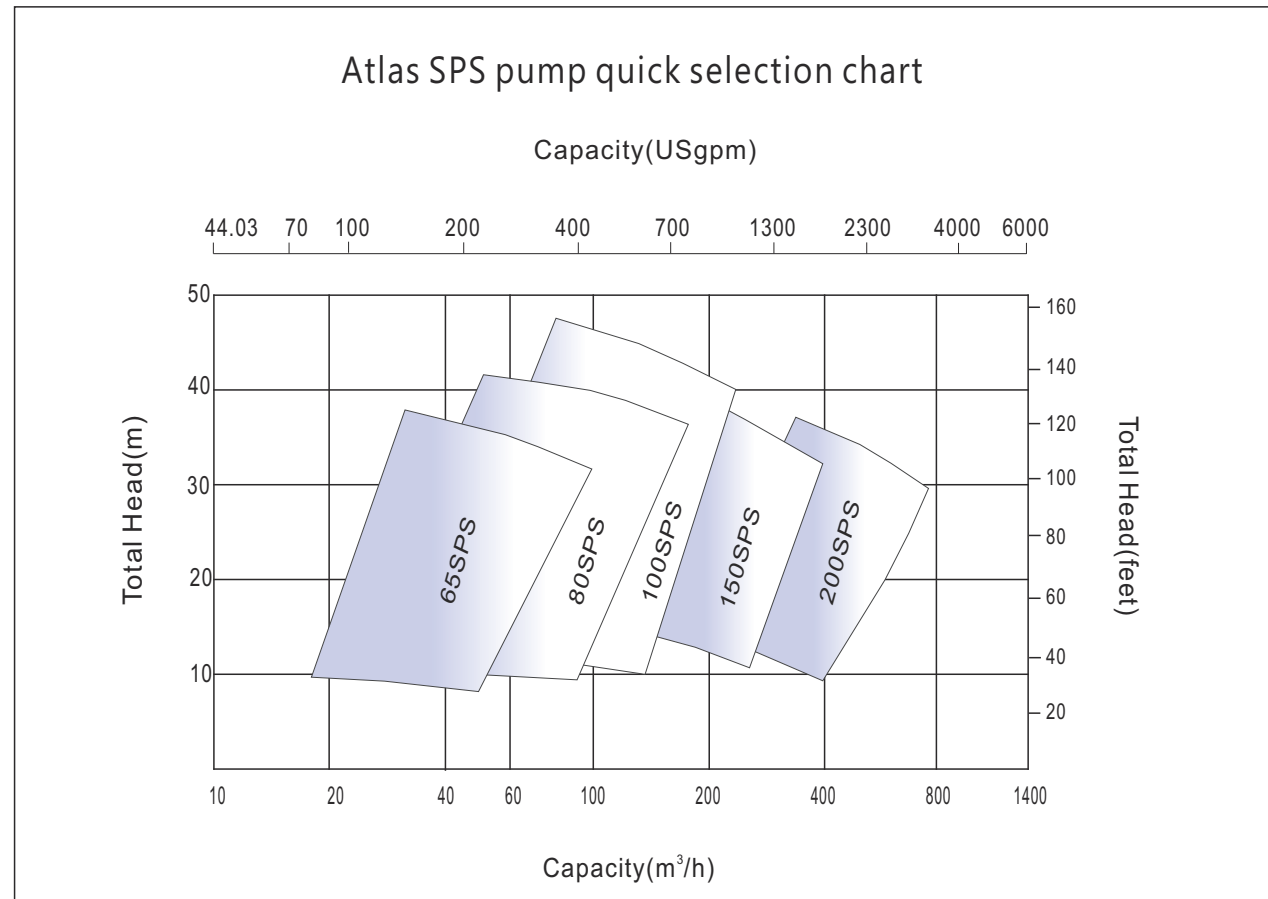

## TYPICAL APPLICATIONS

- Tailing
- Thickener Drainage
- Slag Mills
- Magnetite Mixing
- Coal
- Steel Plant
- Power Plant

The wet parts of SPS are made of high-chrome iron ( ASTM A532 Class III A ), the high hardness will give excellent wear life in most slurry handling applications.

Standard stainless steel( 316) is another option for the wet parts for corrosive applications.

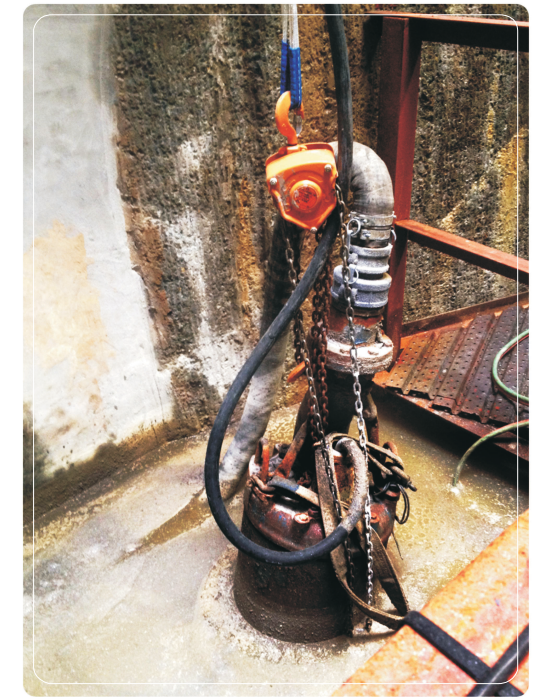

## CLEAR WATER PERFORMANCE

Pump Model	Max. Motor Power(KW)	Clear water performance			
		Capacity Q(m <sup>3</sup> /h)	Head H(m)	Max. Speed n(r/min)	Efficiency η(%)
65SPS	30	15~90	8~35	1780	67
80SPS	45	30~180	10~40	1780	70
100SPS	75	50~210	10~45	1780	73
150SPS	132	100~380	14~36	1480	75
200SPS	160	250~700	10~35	1480	76

## STRUCTURE & FEATURES

- Pump and motor are of one-piece unit design with the impeller and motor sharing the same shaft, ensuring stable operation.
- The pump and motor operate in solution so no priming is needed.
- The pumps do not request fixed supports so can be easily moved as required.
- A Mechanical seal is used to protect the motor from contamination of slurry or liquid so the risk of motor damage will be decreased.
- Less noise and vibration in running condition.
- Wet parts are made of high-chrome alloy or stainless steel, excellent performance to resist wear, corrosion, impact or erosion.
- Different impeller diameters are available to suit different head requirements.
- Otherwise specified, the motors are submersible motors. Please specify or consult Atlas for special requirements

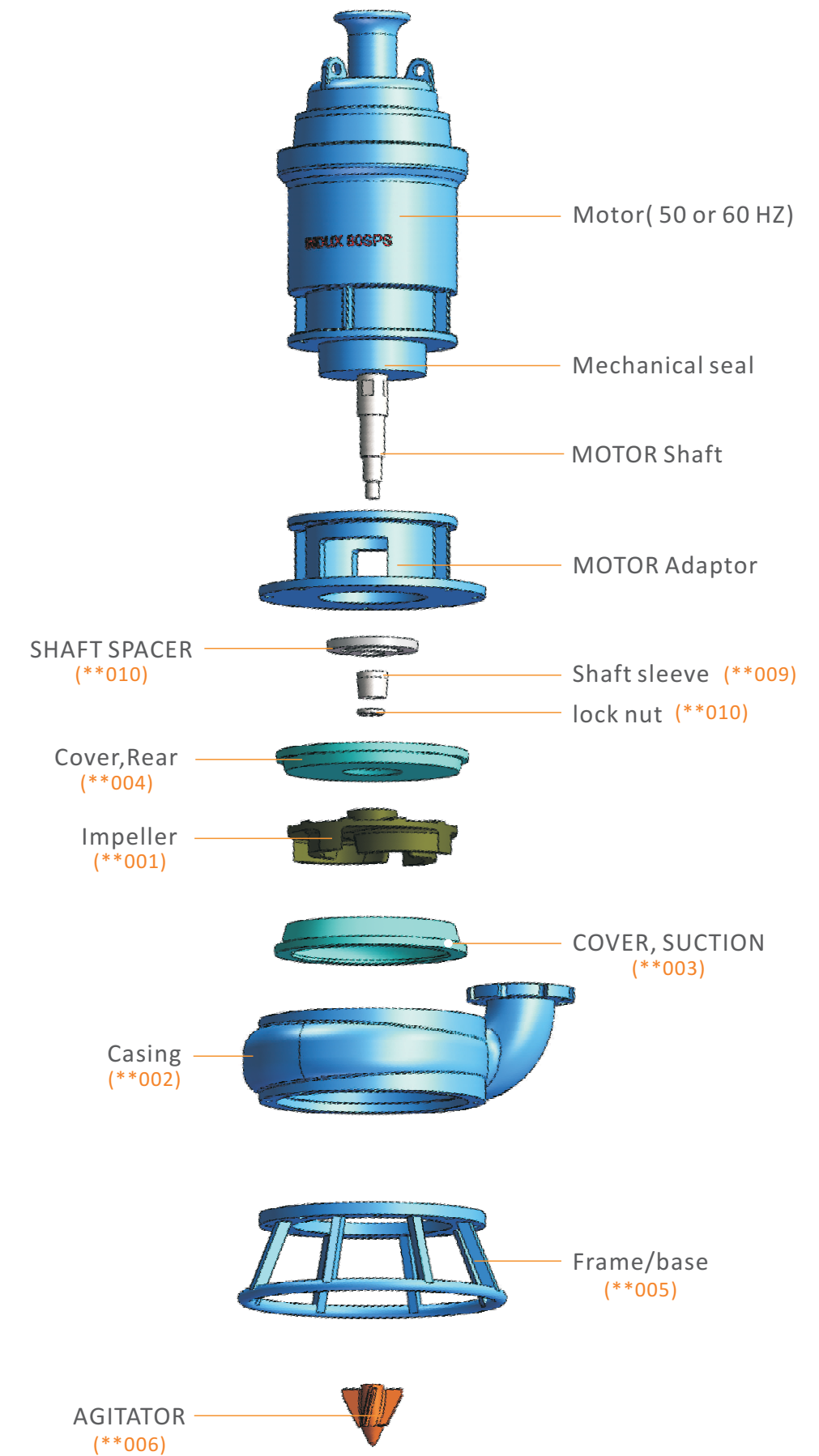
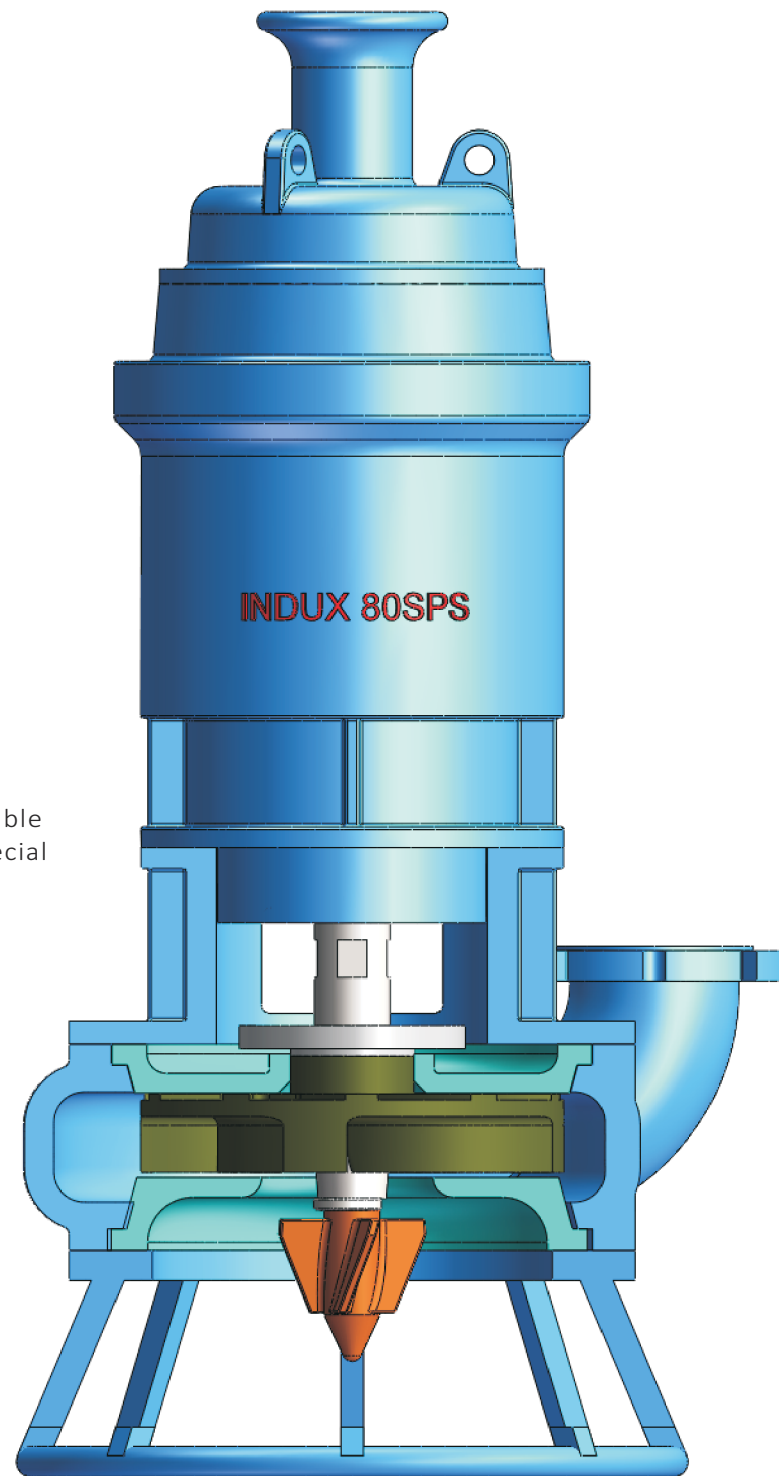

## PUMP INSTALLATION NOTES

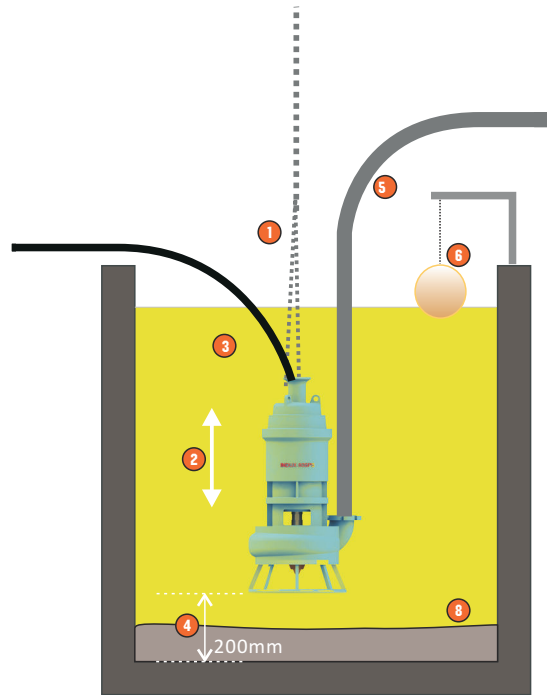

- 1 Never lift or suspend the pump by the electrical cable.
- 2 Ensure that the pump is suspended in a vertical position.
- 3 Always keep the cable away from the rotating inducer.
- 4 Pumps should be suspended by chains, the minimum distance between the bottom of the frame to the pit bottom is 200mm.
- 5 Always use appropriate flexible hose for the pump discharge pipe, do not connect the pump directly to a rigid pipe.
- 6 An automatic switch should be used to turn on and off the motor based on high and low level conditions, float ball or infrared systems are typical.
- 7 Start frequency should not exceed 20starts/hour.
- 8 To ensure even distribution and proper flow, a minimum liquid volume should be ensured, please contact Atlas for sizing.

## OUTLINE DIMENSIONS

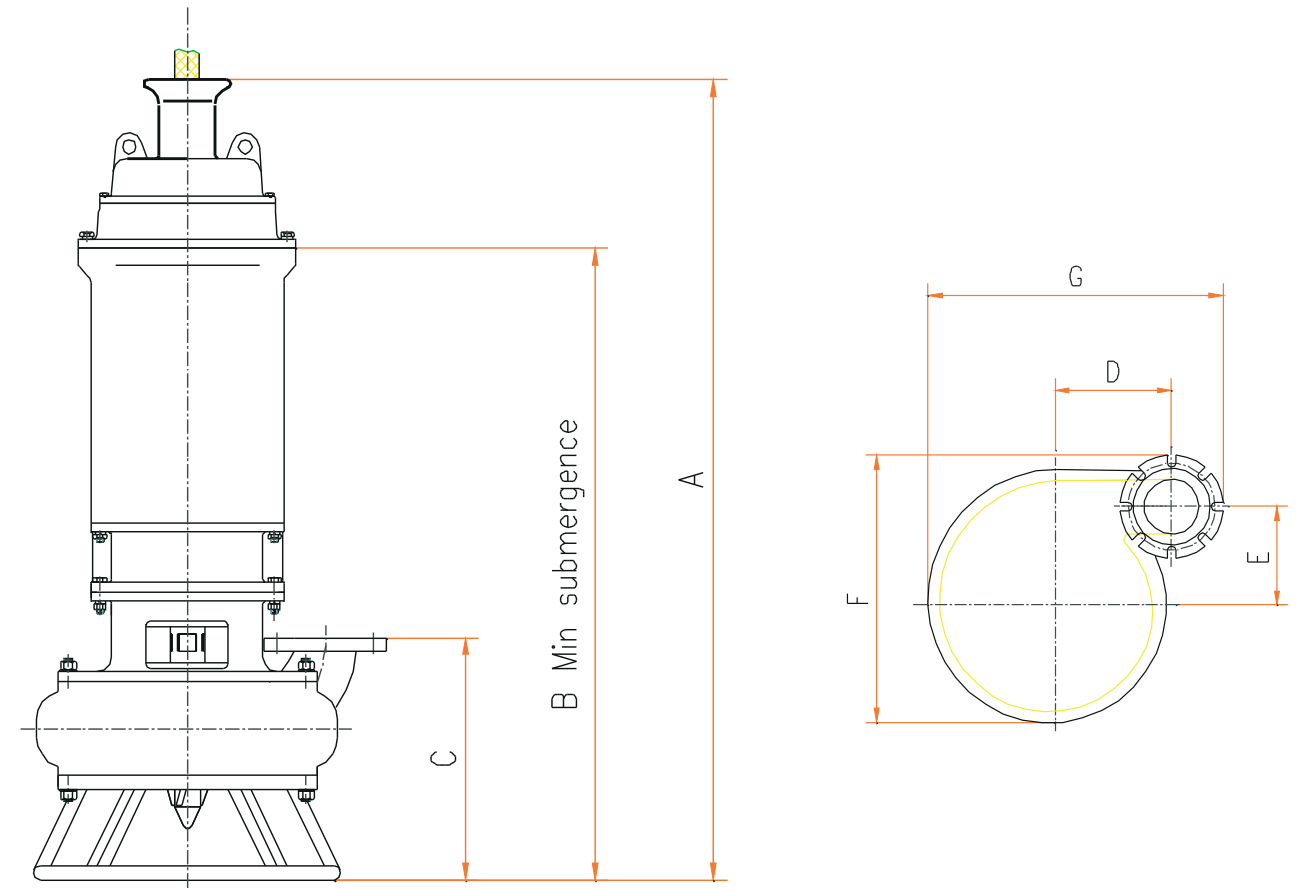

## MATERIAL OPTIONS

### Hard Metals

Material Code	Material Description	Performance Comparison				Applicable Parts		Applications
		Hardness HRC	Anti-Brush	PH Value	Max. Particle Size	Impeller	Liner	
AT01	Medium-Cr Martensitic White Iron	≥55	0.9	3 7 12	—	●	●	Mud & slag applications.
AT03	Ni-Martensitic White Iron	≥56	0.8	—	—	●	●	Neutral water-sand slurry or lower impact load.
AT05	27% Cr White Iron	≥56	1.0 (Datum)	—	—	●	●	High impact load abrasion PH rate ranging from 5 to 12.
AT07	Chromium/Molybdenum	≥58	1.2	—	—	●	●	High impact load abrasion.
AT08	27% Cr White Iron	≥56	1.0	—	—	●	●	Same as AT05, suit for thick wall parts.
AT11	Low Alloy With Iron	38-42	0.7	—	—	●	●	Fine particles, light abrasion.
AT12	30% Cr Hyper eutectic Chromium White Iron	≥62	1.5	—	—	●	—	Highly abrasive, fine particles.
AT33	33% Cr Erosions & Corrosion Resistance White Iron	≥43	0.7	—	—	●	●	Acidic slurries like Phosphoric.
AT49	28% Cr Low Carbon White Iron	≥45	0.7	—	—	●	●	FGD process in power plant
AT530	Super high-Cr White Iron	63-68	1.8	—	—	●	—	Severe abrasive, fine particles.

Pump	A	B	C	D	E	F	G	WT.KG
65SPS	845	673	360	224	176	466	522	590
80SPS	1694	1291	510	395	232	627	773	693
100SPS	2124	1737	758	550	255	705	910	1013
150SPS	2410	1921	758	599	260	745	1085	2373
200SPS	2876	2407	845	656	300	842	1227	2767

All dimensions are in millimeter (mm)